

Features

AF-157

Draw-biased Driver with All Titanium Material



Optimal CG placement for added forgiveness with a draw bias

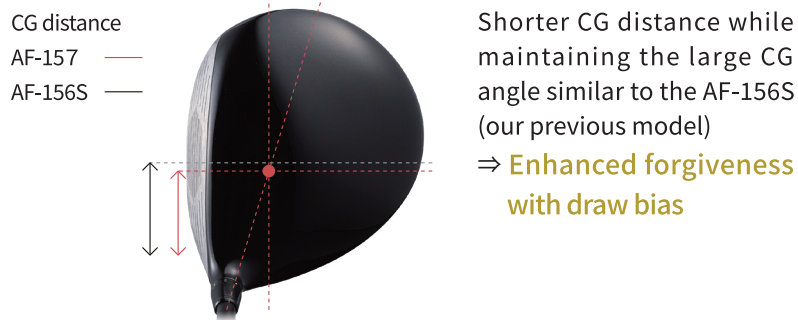

Neo POWER-WAVE Structure

Grooves at face side enhance bow of crown while perpendicular ribs at rear side minimize bow.



The optimal amount of bow produces more ball speed through the dynamic movement of the crown

Results in a higher launch with more spring-like effect

Variable Face Thickness with Dimple Structure

Dimples enhances spring-like effect while maintaining durability of the face

⇒ **Achieve a perfect balance between durability and energy transfer**

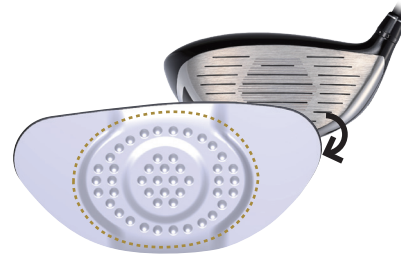

Face back side

Face Lazer Milling

Apply laser milling at impact area on the face

⇒ **Maintain the spin rate in wet conditions similar to that of dry conditions**



[OPTION]

Head Weight Adjustability

The head weight can be reduced up to 4g by changing the optional screw weights

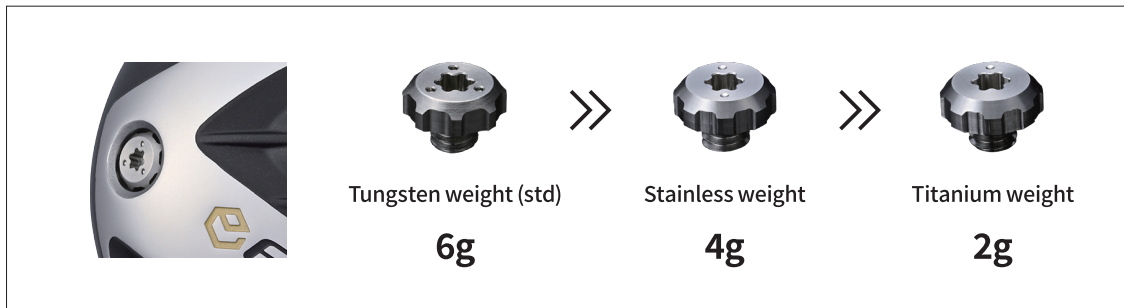

* Please use EPON torque wrench for 8 Angle Dials for the change.

* Please contact our authorized dealers for the change.

* Defects due to replacement of the weight is not covered under EPON warranty.

[8 ANGLE DIALS Position Setting]

Sleeve Position	1	2	3	4	5	6	7	8
F.A.	$\pm 0^\circ$	$\circ 0.5^\circ$	$\circ 1.0^\circ$	$\circ 0.5^\circ$	$\pm 0^\circ$	$c 0.5^\circ$	$c 1.0^\circ$	$c 0.5^\circ$
Lie	$\pm 0^\circ$	$+0.5^\circ$	$+1.0^\circ$	$+1.5^\circ$	$+2.0^\circ$	$+1.5^\circ$	$+1.0^\circ$	$+0.5^\circ$

\circ = OPEN c = CLOSED

* Do not reuse the sleeve.

* Please contact our authorized dealers for adjusting F.A and Lie angle.



EPON torque wrench for 8 ANGLE DIALS

* When using the club, please make sure to tighten the screw with EPON Torque Wrench.

* Do not use other tools except the EPON Torque to tighten the screw.