

Features

S:R Driver

The Longest Driver in EPON History



Any-C System designed for maximum distance

A longer section of the shaft enhances dynamic energy

Approx. 1 inch
Longer Flex Length



Increased head speed delivers
GREATER DISTANCE

Any-C System: Advanced Construction for Explosive Distance

The shaft is free to bend without the hosel

< The hosel bonding area - once rigid in conventional models - is now designed to flex >

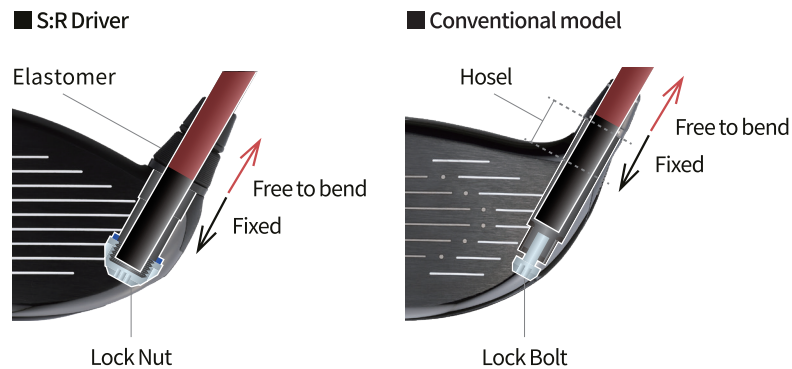

The specialized sleeve and lock nut enable deeper shaft insertion into the lower section of the head
→ Lowered hosel bonding area without upper hosel section *Patent pending technology

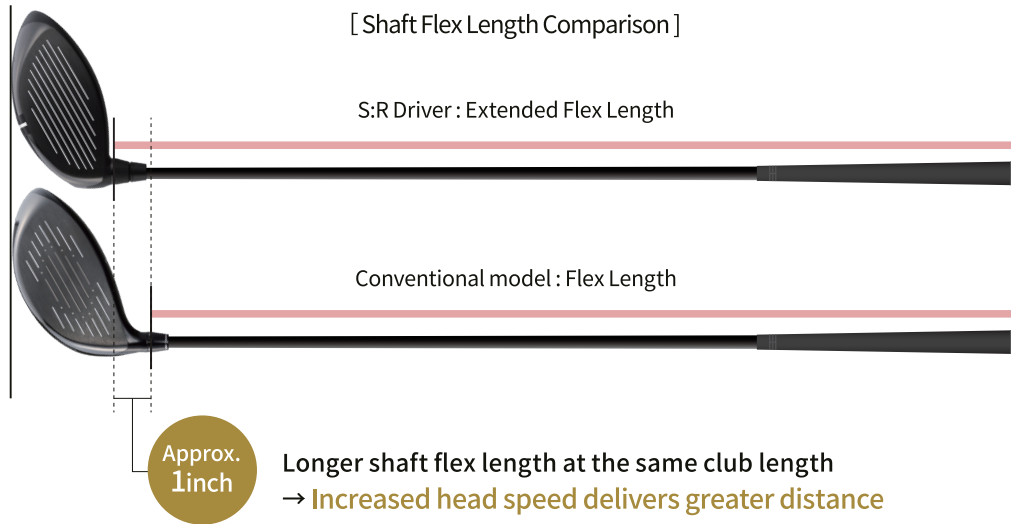

Innovative Head Construction for Maximum Distance

At impact lie angle, the shaft-to-head connection point is lower than the impact point
→ It contributes to higher launch angle and lower spin rate

Enhance distance further



The design promotes upward face orientation at impact
→ Higher launch angle + Gear effect reduces backspin rate



[Conventional Model]

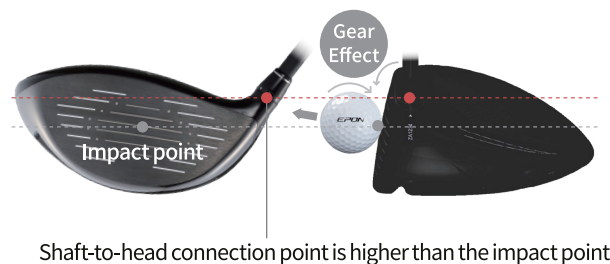

The conventional head design promotes downward face orientation at impact

→ Lower launch angle + Gear effect increases backspin rate

Strategic CG Placement for Enhanced Draw Bias

Optimal deep CG placement
→ Larger CG angle supports the face closure



[OPTION]

Head Weight Adjustment

These weight screws can be replaced with lighter or heavier one to achieve the head weight that you prefer : +6g -2g (2g increment)

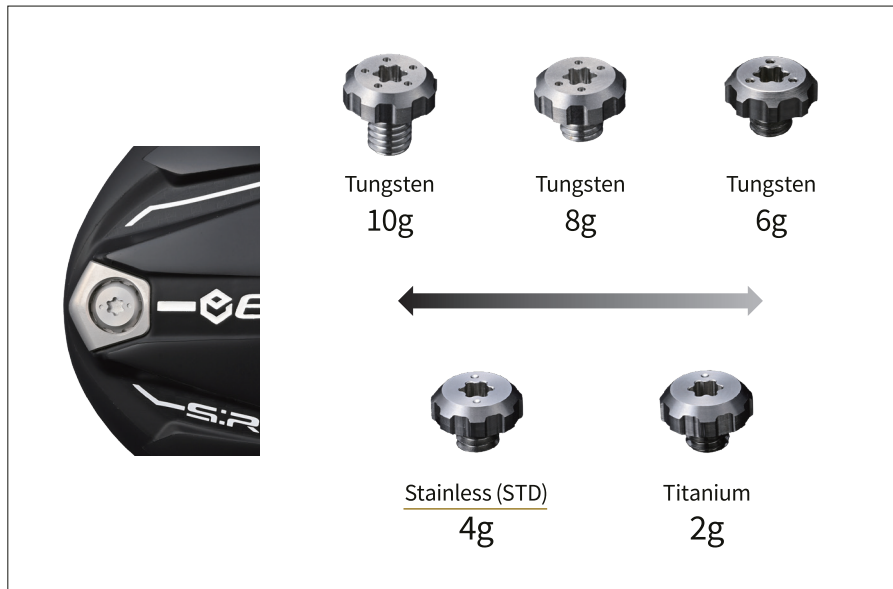

*Please do NOT use S:R Head Torque Wrench for changing these weight screws.

*For weight replacement requests, please contact an authorized EPON GOLF dealer.

*Any damage or malfunction resulting from weight replacement is not covered under warranty.

[8 ANGLE DIALS POSITION SETTING]

Sleeve Position	STD	o0.5+up0.5	o1.0+up1.0	o0.5+up1.5	±0.0+up2.0	c0.5+up1.5	c1.0+up1.0	c0.5+up0.5
F.A.	±0°	o 0.5°	o 1.0°	o 0.5°	±0°	c 0.5°	c 1.0°	c 0.5°
Lie	±0°	+0.5°	+1.0°	+1.5°	+2.0°	+1.5°	+1.0°	+0.5°

o = OPEN c = CLOSED

*Please do NOT reuse the sleeve.

*Please contact our authorized dealers for adjusting FA and lie angle.



S:R Head Torque Wrench

*When using the club, please make sure to tighten the shaft screw with this dedicated torque wrench

*Please do NOT use any other torque wrench for S:R model

S:R Series Club Setting

Simple, intuitive numbering with a performance-driven setup — free from traditional loft and length flow.

	Driver	HYB				Iron						
No.	#1	#2	#3	#4	#5	#6	#7	#8	#9	PW	AW	SW
Loft(°)	10.5/12.5	17	19	21	23	26	29	33	38	43	49	56
Lie(°)	59	58.75	59.5	60.25	61	61.5	62	62.5	63	63.5	63.75	64
Head Weight(g)※	197	220	231	244	255	261	267	274	281	287.5	292	295.5
Club Length(inch)	45.5	42.25	41	39.75	38.5	38	37.5	37	36.5	36	35.75	35.5
Swing Weight	D0.5	D0.5	D0.5	D0.5	D0.5	D0.5	D0.5	D0.5	D0.5	D0.5	D0.5	D0.5
Shaft	DIAMOND SPEEDER 4R	DIAMOND SPEEDER HB 5R				DIAMOND SPEEDER IRON 6R						

Head Weight : Exclude the weight of elastomer & ferrule

Club Length : 60°measuring method